

PERFORMANCE
MADE
SMARTER

Safety manual **9113**

Temperature / mA converter

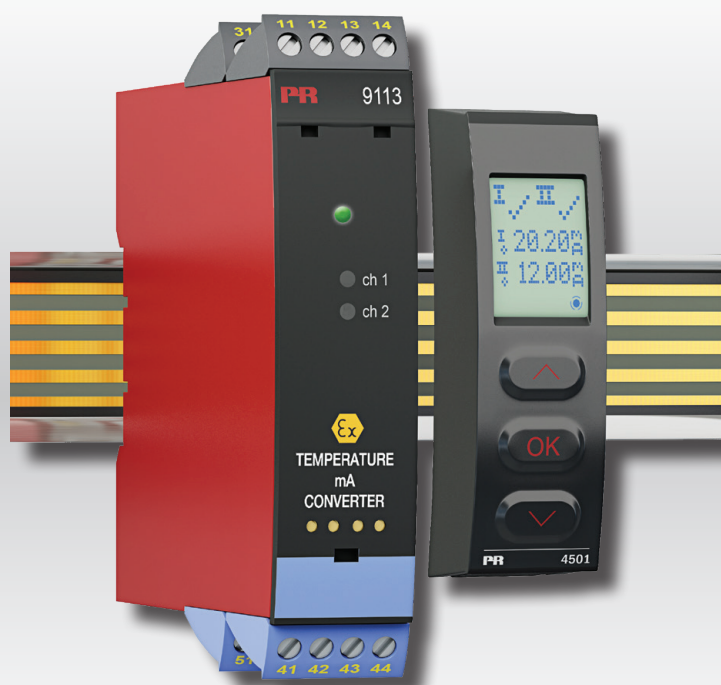

TEMPERATURE | I.S. INTERFACES | COMMUNICATION INTERFACES | MULTIFUNCTIONAL | ISOLATION | DISPLAY

Version No. V8R0

PR
electronics

6 Product Pillars

to meet your every need

Individually outstanding, unrivalled in combination

With our innovative, patented technologies, we make signal conditioning smarter and simpler. Our portfolio is composed of six product areas, where we offer a wide range of analog and digital devices covering over a thousand applications in industrial and factory automation. All our products comply with or surpass the highest industry standards, ensuring reliability in even the harshest of environments and have a 5-year warranty for greater peace of mind.



Temperature

Our range of temperature transmitters and sensors provides the highest level of signal integrity from the measurement point to your control system. You can convert industrial process temperature signals to analog, bus or digital communications using a highly reliable point-to-point solution with a fast response time, automatic self-calibration, sensor error detection, low drift, and top EMC performance in any environment.



I.S. Interface

We deliver the safest signals by validating our products against the toughest safety standards. Through our commitment to innovation, we have made pioneering achievements in developing I.S. interfaces with SIL 2 Full Assessment that are both efficient and cost-effective. Our comprehensive range of analog and digital intrinsically safe isolation barriers offers multifunctional inputs and outputs, making PR an easy-to-implement site standard. Our backplanes further simplify large installations and provide seamless integration to standard DCS systems.



Communication

We provide inexpensive, easy-to-use, future-ready communication interfaces that can access your PR installed base of products. All the interfaces are detachable, have a built-in display for readout of process values and diagnostics, and can be configured via push-buttons. Product specific functionality includes communication via Modbus and Bluetooth and remote access using our PR Process Supervisor (PPS) application, available for iOS, Android and Windows.



Multifunction

Our unique range of single devices covering multiple applications is easily deployable as your site standard. Having one variant that applies to a broad range of applications can reduce your installation time and training, and greatly simplify spare parts management at your facilities. Our devices are designed for long-term signal accuracy, low power consumption, immunity to electrical noise and simple programming.



Isolation

Our compact, fast, high-quality 6 mm isolators are based on microprocessor technology to provide exceptional performance and EMC-immunity for dedicated applications at a very low total cost of ownership. They can be stacked both vertically and horizontally with no air gap separation between units required.



Display

Our display range is characterized by its flexibility and stability. The devices meet nearly every demand for display readout of process signals, and have universal input and power supply capabilities. They provide a real-time measurement of your process value no matter the industry, and are engineered to provide a user-friendly and reliable relay of information, even in demanding environments.

SAFETY MANUAL

TEMPERATURE / mA CONVERTER 9113

This safety manual is valid for the following product versions:

9113-004
9113-003
9113-002

1. Observed standards	5
2. Acronyms and abbreviations.....	5
3. Purpose of the product.....	5
4. Assumptions and restrictions for use of the product	5
4.1 Basic safety specifications.....	5
4.2 Safety accuracy.....	5
4.2.1 Minimum span	6
4.2.2 Range limitations.....	6
4.3 Associated equipment	6
4.3.1 RTD sensor wiring	6
4.3.2 Sensor errors.....	6
4.3.3 Process calibration	6
4.3.4 Analog output	6
4.4 Failure rates	6
4.5 Safe parameterization.....	6
4.6 Installation in hazardous areas	6
5. Functional specification of the safety function.....	6
6. Functional specification of the non-safety functions.....	7
7. Safety parameters.....	7
8. Hardware and software configuration.....	7
9. Failure category	7
10. Periodic proof test procedure.....	8
11. Procedures to repair or replace the product	8
12. Maintenance.....	8
13. Documentation for routing diagram	8
13.1 In general	8
13.2 Further explanations.....	8
13.2.1 Password protection.....	8
13.2.2 Sensor/cable fault information via display front 45xx	8
13.3 Advanced functions (ADV.SET).....	8
13.3.1 Memory (MEM)	8
13.3.2 Display setup (DISP)	9
13.3.3 Password (PASS).....	9
13.3.4 Language (LANG).....	9
13.3.5 Process calibration (CAL)	9
13.3.6 Power rail (RAIL).....	9
13.3.7 Simulation (SIM).....	9
13.3.8 Safety integrity level (SIL)	9
14. Safe parameterization - user responsibility	9
14.1 Safety-related configuration parameters	9
14.1.1 Parameters related only to Channel 1	9
14.1.2 Parameters related only to Channel 2 (only for type 9113BB).....	11
14.1.3 Parameters related to both channels	11

14.2	Verification procedure.....	11
14.2.1	If no password is set	11
14.2.2	If password is set.....	13
14.2.3	If any parameter is found to be incorrect during verification	13
14.3	Functional test.....	13
15.	Fault reaction and restart condition.....	13
16.	User interface	14
16.1	Scrolling help texts in display line 3	14
16.2	Routing diagram.....	15
16.3	Routing diagram, advanced settings (ADV.SET).....	17
17.	Connections diagram	18

1. Observed standards

Standard	Description
IEC 61508	Functional Safety of electrical / electronic / programmable electronic safety-related systems
IEC 61508-2:2000	Part 2: Requirements for electrical / electronic / programmable electronic safety-related systems
IEC 61508-3:1998	Part 3: Software requirements
IEC 61326-3-1:2008	Immunity requirements for safety-related systems

2. Acronyms and abbreviations

Acronym / Abbreviation	Designation	Description
Element		Term defined by IEC 61508 as "part of a subsystem comprising a single component or any group of components that performs one or more element safety functions"
PFD	Probability of Failure on Demand	This is the likelihood of dangerous safety function failures occurring on demand.
PFH	Probability of dangerous Failure per Hour	The term "Probability" is misleading, as IEC 61508 defines a Rate.
SFF	Safe Failure Fraction	Safe Failure Fraction summarizes the fraction of failures which lead to a safe state and the fraction of failures which will be detected by diagnostic measures and lead to a defined safety action.
SIF	Safety Integrity Function	Function that provides fault detection (to ensure the necessary safety integrity for the safety functions)
SIL	Safety Integrity Level	The international standard IEC 61508 specifies four discrete safety integrity levels (SIL 1 to SIL 4). Each level corresponds to a specific probability range regarding the failure of a safety function.

3. Purpose of the product

Conversion and scaling of temperature (Pt, Ni and TC) and current signals from hazardous area.

The device can be mounted in the safe area and in zone 2 / div. 2 and receive signals from zone 0, 1, 2, 20, 21 and 22 / Class I/II/III, Div. 1, Gr. A-G.

Error events, including cable breakage, are monitored and signalled via the individual status relay and/or a collective electronic signal via the power rail.

The 9113 has been designed, developed and certified for use in SIL 2 applications according to the requirements of IEC 61508.

4. Assumptions and restrictions for use of the product

4.1 Basic safety specifications

Operational temperature range	-20...+60°C
Storage temperature range.	-20...+85°C
Power supply type, min.	Double or reinforced
Supply voltage	19.2...31.2 VDC
External loop supply voltage.	5...26 VDC + external drop
Mounting area	Zone 2 / Division 2 or safe area
Mounting environment	Pollution degree 2 or better

4.2 Safety accuracy

The analog output and relay output corresponds to the applied input within the safety accuracy.

Safety accuracy ±2%

4.2.1 Minimum span

For temperature measurements, the selected range (OUT.HI - OUT.LO) shall be larger or equal to the values below:

Input type	Minimum span for safety accuracy
Pt100, Pt200, Pt1000	28°C
Pt500, Ni100, Ni120, Ni1000	43°C
Pt50, Pt400, Ni50	57°C
Pt250, Pt300	85°C
Pt20	142°C
Pt10	283°C
TC: E, J, K, L, N, T, U	91°C
TC: B, R, S, W3, W5, LR	153°C

4.2.2 Range limitations

TC type B shall not be used below +400°C

4.3 Associated equipment**4.3.1 RTD sensor wiring**

If a 2-wire or a 3-wire connection for RTD is selected, the end user must ensure that the applied sensor wiring does not introduce failures exceeding the requirements for the safety application.

4.3.2 Sensor errors

If Sensor error detection is disabled, if current input range 0...20 mA is selected or if input type Pt10, Pt20, or Pt50 is selected, the end user must ensure that the applied sensor including wiring has a failure rate qualifying it for the safety application without sensor error detection enabled.

For Pt10, Pt20 and Pt50 input types, this only relates to short-circuited sensor detection.

4.3.3 Process calibration

If a process calibration is taken into SIL-mode operation, it is mandatory that the accuracy of the device (and sensor, if applicable) are tested by the end user after SIL-mode is entered, in addition to the normal functional test. Refer to section 14 - Safe parameterization - user responsibility.

4.3.4 Analog output

The connected safety PLC shall be able to detect and handle the fault indications on the analog output of the 9113 converter by having a NAMUR NE43-compliant current input.

4.4 Failure rates

The basic failure rates from the Siemens standard SN 29500 are used as the failure rate database.

Failure rates are constant, wear-out mechanisms are not included.

External power supply failure rates are not included.

4.5 Safe parameterization

The user is responsible for verifying the correctness of the configuration parameters. (See section 14 Safe parameterization - user responsibility).

Manual override may not be used for safety applications.

4.6 Installation in hazardous areas

The IECEx Installation drawing, ATEX Installation drawing and FM Installation drawing shall be followed if the products are installed in hazardous areas.

5. Functional specification of the safety function

Conversion of current signals (0...20 mA or 4...20 mA), RTD sensor signals or thermocouple sensor signals from hazardous areas to a 4...20 mA current output signal, in two separately configurable channels, within specified accuracy.

For RTD sensors, cable resistances of up to 50 Ω per wire can be compensated if 3- or 4-wire connection is configured.

For thermocouple sensors, cold junction temperature errors can be compensated, either by an internally mounted temperature sensor, or by an accessory connector with a built-in temperature sensor. The selection of CJC measurement must be done and verified by the end user.

6. Functional specification of the non-safety functions

The status relay (terminal 33 and 34), error signal on power rail (terminal 91) and LED outputs are not suitable for use in any Safety Instrumented Function.

7. Safety parameters

Probability of dangerous Failure per Hour (PFH)	6.10E-08
	Note ¹
Probability of failure on demand (PFD) - 1 year proof test interval	3.96E-04
Proof test interval (10% of loop PFD)	3 years
Safe Failure Fraction	90.7%
Demand response time	Signal input: < 0.5 seconds Temperature input: < 1.1 seconds
Demand mode	High
Demand rate	3000 seconds
Mean Time To Repair (MTTR)	24 hours
Diagnostic test interval	30 seconds
Hardware Fault Tolerance (HFT)	0
Component Type	B
SIL capability	SIL 2
Description of the "Safe State"	Output \leq 3.6 mA or output \geq 21 mA

Note¹: The 9113 contains no lifetime limiting components, therefore the PFH figures are valid for up to 12 years, according to IEC 61508.

8. Hardware and software configuration

All configurations of software and hardware versions are fixed from factory, and cannot be changed by end-user or reseller. This manual only covers products labelled with the product version (or range of versions) specified on the front page.

9. Failure category

Failure category	Failure rates (1/h)
Fail Safe Detected	0.00E+00
Fail Safe Undetected	2.34E-7
Fail Dangerous Detected	3.67E-7
Fail Dangerous Undetected	6.10E-8

10. Periodic proof test procedure

Step	Action
1	Bypass the safety PLC or take other appropriate action to avoid a false trip
2	Connect a simulator identical to the input setup
3	Apply input value corresponding to 0/100% output range to each channel
4	Observe whether the output channel acts as expected
5	Restore the input terminals to full operation
6	Remove the bypass from the safety PLC or otherwise restore normal operation

This test will detect approximately 95% of possible "du" (dangerous undetected) failures in the pulse isolator. The proof test is equivalent to the functional test.

11. Procedures to repair or replace the product

Any failures that are detected and that compromise functional safety should be reported to the sales department at PR electronics A/S.

Repair of the module and replacement of circuit breakers must be done by PR electronics A/S only.

12. Maintenance

No maintenance required.

13. Documentation for routing diagram

The routing diagram is shown in section 16.2.

13.1 In general

When configuring the 9113, you will be guided through all parameters and you can choose the settings which fit the application. For each menu there is a scrolling help text which is automatically shown in line 3 on the display.

Configuration is carried out by use of the 3 function keys:

- ⏪ will increase the numerical value or choose the next parameter
- ⏩ will decrease the numerical value or choose the previous parameter
- ⏹ will accept the chosen value and proceed to the next menu

When configuration is completed, the display will return to the default state 1.0.

Pressing and holding ⏹ will return to the previous menu or return to the default state (1.0) without saving the changed values or parameters.

If no key is activated for 1 minute, the display will return to the default state (1.0) without saving the changed values or parameters.

13.2 Further explanations

13.2.1 Password protection

Password protection: Programming access can be blocked by assigning a password. The password is saved in the device in order to ensure a high degree of protection against unauthorized modifications to the configuration. If the configured password is not known, please contact PR electronics support - www.prelectronics.com/contact.

Password protection is mandatory in SIL applications.

13.2.2 Sensor/cable fault information via display front 45xx

When the function is enabled and supported by selected input type, sensor or cable faults are displayed as SE.BR (sensor break) or SE.SH (cable short-circuited). Sensor fault is shown independently for each channel. In case of sensor or cable fault the backlight flashes. This can be reset by pressing the ⏹ key. When the sensor or cable fault has been remedied, the device will return to normal operation.

13.3 Advanced functions (ADV.SET)

The device gives access to a number of advanced functions which can be reached by answering "Yes" to the point "ADV.SET".

13.3.1 Memory (MEM)

In the memory menu a non-SIL configuration can be either saved or loaded from the local memory of the 45xx display unit. Choose SAVE to store the current configuration in the 45xx memory. Press LOAD to read a previously stored configuration in the 45xx memory and store it in the device. It is only possible to load a configuration stored from the same type of device and from the same version, or earlier.

13.3.2 Display setup (DISP)

The brightness contrast and the backlight can be adjusted.

Tag numbers with 5 alphanumeric characters can be entered for both channels.

Functional readout in line 2 (ch.1) and 3 (Ch.2) of the display can be selected: choose between readout of input value, output current or tag no.

When selecting "ALT" the readout alternates between input value, output current and tag no.

13.3.3 Password (PASS)

Here you can choose a password between 0000 and 9999 in order to protect the device against unauthorized modifications to the configuration. The device is delivered default without password.

13.3.4 Language (LANG)

In this menu you can choose between 7 different language versions of help texts that will appear in the menu. You can choose between UK, DE, FR, IT, ES, SE and DK.

13.3.5 Process calibration (CAL)

A process calibration can be made by the end user. A known process signal must be applied for both low and high end of the input measurement range. The known input of the applied low end signal must be entered in the CAL.LO menu and confirmed by pressing OK before removing or changing the applied signal to the high end signal. The known input of the applied high end signal must be entered in the CAL.HI menu and confirmed by pressing OK before removing. It is possible to enable or disable the use of the latest process calibration.

13.3.6 Power rail (RAIL)

In this menu it can be chosen if sensor errors are transmitted to the central surveillance in the PR 9410 power control device.

13.3.7 Simulation (SIM)

It is possible to override the actual measured input signal by a simulated value. Only one channel can be simulated at a time. Leaving either of the simulation menus, or disconnecting the 45xx device, will disable the simulation mode and bring the output back to correspond to the actual measured value. Simulation is not possible in SIL-mode.

13.3.8 Safety integrity level (SIL)

See section 14 - Safe parameterization - user responsibility

14. Safe parameterization - user responsibility**14.1 Safety-related configuration parameters****14.1.1 Parameters related only to Channel 1**

Name	Function
CH1.TYP	Selected input type: TEMP = Temperature CURR = Current
I.RANGE	Selected fixed input range for current measurements (for CH1.TYPE = CURR): 0_20 = 0...20 mA (no sensor error detection!) 4_20 = 4...20 mA
CONNEX	Selected sensor connection type for RTD measurements (for SENSOR = Ni or Pt): 2W = 2-wire 3W = 3-wire 4W = 4-wire If 2W or 3W is selected, the end user must ensure that the applied sensor wiring does not introduce failures exceeding the requirements for the safety application.
UNIT	Selected temperature unit (for CH1.TYP = TEMP): °C = degrees Celsius °F = degrees Fahrenheit
SENSOR	Selected temperature sensor type (for CH1.TYPE = TEMP): TC = Thermocouple Ni = Ni RTD sensor Pt = Pt RTD sensor

Pt.TYPE	Pt sensor type (for SENSOR = Pt): 10 = Pt10 20 = Pt20 50 = Pt50 100 = Pt100 200 = Pt200 250 = Pt250 300 = Pt300 400 = Pt400 500 = Pt500 1000 = Pt1000 } (No short circuit detection!)
Ni.TYPE	Ni sensor type (for SENSOR = Ni): 50 = Ni50 100 = Ni100 120 = Ni120 1000 = Ni1000
TC.TYPE	Thermocouple type (for SENSOR = TC): TC.B = Thermocouple type B TC.E = Thermocouple type E TC.J = Thermocouple type J TC.K = Thermocouple type K TC.L = Thermocouple type L TC.N = Thermocouple type N TC.R = Thermocouple type R TC.S = Thermocouple type S TC.T = Thermocouple type T TC.U = Thermocouple type U TC.W3 = Thermocouple type W3 TC.W5 = Thermocouple type W5 TC.Lr = Thermocouple type Lr
CJC	CJC type for SENSOR = TC: INT = Internal CJC sensor measurement CONN = CJC connector measurement (accessory)
O.RANGE	Fixed output range for current output: 0-20 = 0...20 mA Not valid when EN.SIL = YES (Safety applications) 4-20 = 4...20 mA 20-0 = 20...0 mA Not valid when EN.SIL = YES (Safety applications) 20-4 = 20...4 mA
OUT.ERR	Fixed output value on detected sensor error: NONE = Sensor error detection NOT enabled, output at sensor error is undefined. The end user must ensure that the applied sensor including wiring has a failure rate qualifying it for the safety application without the detection enabled. 0 mA = Output is 0 mA at sensor error 3.5 mA = Output is 3.5 mA at sensor error (NE43 downscale) 23 mA = Output is 23 mA at sensor error (NE4 upscale)
OUT.LO	Selected temperature value for 0% output for CH1.TYP = TEMP in units defined by the UNIT parameter (°C or °F) Range is defined by the selected temperature sensor (SENSOR and TC.TYPE, Ni.TYPE or Pt.TYPE), but value must be less than OUT.HI - minimum span.
OUT.HI	Selected temperature value for 100% output for CH1.TYP = TEMP in units defined by the UNIT parameter (°C or °F). Range is defined by the selected temperature sensor (SENSOR and TC.TYPE, Ni.TYPE or Pt.TYPE), but must be larger than OUT.LO + minimum span.
RESP	Analog output response time in seconds. Range is 0.0 to 60.0 seconds.
USE.CAL	Use the applied process calibration values: NO = The last performed process calibration on Channel1 is not used. The channel operates with accuracy as specified. YES = The last performed process calibration on Channel1 is in operation. The required accuracy must be verified by user. End user must verify by test that the applied process calibration does not introduce failures exceeding the requirements for the safety application.

14.1.2 Parameters related only to Channel 2 (only for type 9113BB)

Name	Function
CH2.TYP	Functions as described for Channel 1 (14.1.1)
I.RANGE	
CONNEC	
UNIT	
SENSOR	
Pt.TYPE	
Ni.TYPE	
TC.TYPE	
CJC	
O.RANGE	
OUT.ERR	
OUT.LO	
OUT.HI	
RESP	
USE.CAL	

14.1.3 Parameters related to both channels

Name	Function
NEW.PAS	Password for protection of the device configuration from un-authorized access. Range from 0 to 9999.

The above safety-related configuration parameters are marked in red text in the routing diagrams and must be verified by the user in a SIL configuration.

14.2 Verification procedure

The verification is done using the display / programming front PR 45xx and following the procedure described below.

14.2.1 If no password is set

	Action	Display shows
1	Press OK	ADV.SET
2	Set (ADV.SET) to Yes and press OK	SETUP
3	Set SETUP to SIL and press OK	EN.SIL
4	Set EN.SIL to YES and press OK	NEW.PAS
5	Set password to a number between 0 and 9999 and press OK (At this time the device starts operating in SIL mode with the entered configuration parameters!)	CONFIG Verify OPEN->LOCK*
6	Press OK to confirm verification of the OPEN->LOCK in the display	CH1.TYPE
7	Verify input type for Channel 1 and press OK	I.RANGE
8	Verify fixed input range and press OK (ONLY IF CH1.TYP = CURR)	CONNEC
9	Verify sensor connection type and press OK (ONLY IF SENSOR = Ni or Pt and CH1.TYP = TEMP)	UNIT
10	Verify temperature unit and press OK (ONLY IF CH1.TYP = TEMP)	SENSOR

* Open is shown briefly in the display.

11	Verify temperature sensor type and press OK (ONLY IF CH1.TYP = TEMP)	Pt.TYPE
12	Verify Pt sensor type and press OK (ONLY IF SENSOR = Pt and CH1.TYP = TEMP)	Ni.TYPE
13	Verify Ni sensor type and press OK (ONLY IF SENSOR = Ni and CH1.TYP = TEMP)	TC.TYPE
14	Verify Thermocouple type and press OK (ONLY IF SENSOR = TC and CH1.TYP = TEMP)	CJC
15	Verify CJC type and press OK (ONLY IF SENSOR = TC and CH1.TYP = TEMP)	O.RANGE
16	Verify fixed output range and press OK	OUT.ERR
17	Verify fixed output value on detected sensor error and press OK (ONLY IF CH1.TYP = TEMP, or IF I.RANGE = 4-20 mA)	OUT.LO
18	Verify temperature for 0% output and press OK (ONLY IF CH1.TYP = TEMP)	OUT.HI
19	Verify temperature for 100% output and press OK (ONLY IF CH1.TYP = TEMP)	RESP
20	Verify analog output response time and press OK	CH2.TYP
21	Verify input type for Channel 2 and press OK	I.RANGE
22	Verify fixed input range and press OK (ONLY IF CH2.TYP = CURR)	CONNEC
23	Verify sensor connection type and press OK (ONLY IF SENSOR = Ni or Pt and CH2.TYP = TEMP)	UNIT
24	Verify temperature unit and press OK (ONLY IF CH2.TYP = TEMP)	SENSOR
25	Verify temperature sensor type and press OK (ONLY IF CH2.TYP = TEMP)	Pt.TYPE
26	Verify Pt sensor type and press OK (ONLY IF SENSOR = Pt and CH2.TYP = TEMP)	Ni.TYPE
27	Verify Ni sensor type and press OK (ONLY IF SENSOR = Ni and CH2.TYP = TEMP)	TC.TYPE
28	Verify Thermocouple type and press OK (ONLY IF SENSOR = TC and CH2.TYP = TEMP)	CJC
29	Verify CJC type and press OK (ONLY IF SENSOR = TC and CH2.TYP = TEMP)	O.RANGE
30	Verify fixed output range for current output	OUT.ERR
31	Verify fixed output value on detected sensor error and press OK (ONLY IF CH2.TYP = TEMP, or IF I.RANGE = 4-20 mA or 20-4 mA)	OUT.LO
32	Verify temperature for 0% output and press OK (ONLY IF CH2.TYP = TEMP)	OUT.HI
33	Verify temperature for 100% output and press OK (ONLY IF CH2.TYP = TEMP)	RESP
34	Verify analog output response time and press OK	CH1.CAL
35	Verify the use of applied process calibration values for Channel 1 and press OK	CH2.CAL
36	Verify the use of applied process calibration values for Channel 2 and press OK	PASSW.
37	Verify password and press OK	SIL.OK
38	Verify SIL mode within 1 second	

14.2.2 If password is set

	Action	Display shows
1	Press OK	PASSW
2	Enter password and press OK	ADV.SET
3	Set ADV.SET to Yes and press OK	SETUP
4	Set SETUP to SIL and press OK	EN.SIL
5	Set EN.SIL to YES and press OK (At this time the device starts operating in SIL mode with the entered configuration parameters!)	CONFIG Verify OPEN->LOCK*
6 to 38	As step 6 to 38 for 14.2.1	As step 6 to38 for 14.2.1

* Open is shown briefly in the display

14.2.3 If any parameter is found to be incorrect during verification

Remove SIL-mode (by entering the password and setting EN.SIL to NO in the "ADV.SET -> SIL" setup menu).
Go through the setup menu and correct the parameter(s).
Repeat step 1 to 38 (with correct parameters).

14.3 Functional test

The user is responsible to make a functional test after verification of the safety parameters. The procedure for periodic proof test described in section 10 shall be used.

In addition, if a process calibration is taken into SIL-mode operation (refer to section 13.3 - Advanced functions), it is mandatory that the accuracy of the device (and sensor, if applicable) are tested.

15. Fault reaction and restart condition

When the 9113 detects a fault the output will go to Safe State, in which the output will go to "de-energized".

If the fault is application-specific (cable error detection) the 9113 will restart when the fault has been corrected.

For device faults there are 2 ways of bringing the device out of Safe State.

1. Power cycle the device.

2. Bring the device out of SIL mode (choose "NO" in the menu point "EN.SIL"), and set it back to SIL mode again (choose "YES" in the menu point "EN.SIL" and verify the configuration).

16. User interface

16.1 Scrolling help texts in display line 3

- | | | | |
|------|--|------|---|
| [01] | Set correct password | [17] | Enter SIL setup |
| [02] | Enter advanced setup menu? | | Enter simulation mode |
| [03] | Select temperature input | | Enter RAIL setup |
| | Select current input | | Perform process calibration |
| [04] | Select 0-20 mA input range | | Enter language setup |
| | Select 4-20 mA input range | | Enter password setup |
| [05] | Select TC sensor type | | Enter display setup |
| | Select Ni sensor type | | Perform memory operations |
| | Select Pt sensor type | [18] | Load saved configuration into 9113 |
| [06] | Select Pt10 sensor type | | Save 9113 configuration in 45xx |
| | Select Pt20 sensor type | [19] | Adjust LCD contrast |
| | Select Pt50 sensor type | [20] | Adjust LCD backlight |
| | Select Pt100 sensor type | [21] | Write a 5-character channel TAG |
| | Select Pt200 sensor type | [22] | Show analog input value in display |
| | Select Pt250 sensor type | | Show analog output value in display |
| | Select Pt300 sensor type | | Show TAG in display |
| | Select Pt400 sensor type | | Alternate shown information in display |
| | Select Pt500 sensor type | [23] | Enable password protection? |
| | Select Pt1000 sensor type | [24] | Set new password |
| [07] | Select Ni50 sensor type | [25] | Select language |
| | Select Ni100 sensor type | [26] | Select channel to calibrate |
| | Select Ni120 sensor type | [27] | Calibrate input low to process value? |
| | Select Ni1000 sensor type | [28] | Set value for low calibration point |
| [08] | Select TC-B sensor type | [29] | Calibrate input high to process value? |
| | Select TC-E sensor type | [30] | Set value for high calibration point |
| | Select TC-J sensor type | [31] | Use process calibration values? |
| | Select TC-K sensor type | [32] | Select channel to simulate |
| | Select TC-L sensor type | [33] | Set the input simulation value |
| | Select TC-N sensor type | [34] | Enable SIL configuration lock? |
| | Select TC-R sensor type | | 0-20 mA is not a valid output range for SIL operation |
| | Select TC-S sensor type | [35] | Set Analog output response time in seconds |
| | Select TC-T sensor type | [36] | Select internal temperature sensor |
| | Select TC-U sensor type | | Select CJC connector (accessory) |
| | Select TC-W3 sensor type | [37] | ...is channel using process-compensated calibration data? |
| | Select TC-W5 sensor type | [38] | Configuration SIL status (Open / Locked) |
| [09] | Select 2-wire sensor connection | [40] | Sensor wire breakage |
| | Select 3-wire sensor connection | [41] | Sensor short circuit |
| | Select 4-wire sensor connection | [42] | Input underrange |
| [11] | Select Celsius as temperature unit | [43] | Input overrange |
| | Select Fahrenheit as temperature unit | [44] | Input error - check input connections and reset power |
| [12] | Select 0-20 mA output range | [45] | Output error - check connections and reset power |
| | Select 4-20 mA output range | [46] | Flash memory error - check configuration |
| | Select 20-0 mA output range | [47] | Invalid configuration type or version |
| | Select 20-4 mA output range | [48] | Hardware error |
| [13] | Select no error action - output undefined at error | [49] | CJC sensor error - check device temperature |
| | Select downscale at error | [50] | CJC error - check CJC connector block |
| | Select NAMUR NE43 downscale at error | [51] | No communication |
| | Select NAMUR NE43 upscale at error | | |
| [14] | Set temperature for analog output low | | |
| [15] | Set temperature for analog output high | | |
| [16] | Enable Rail status signal output? | | |

16.2 Routing diagram

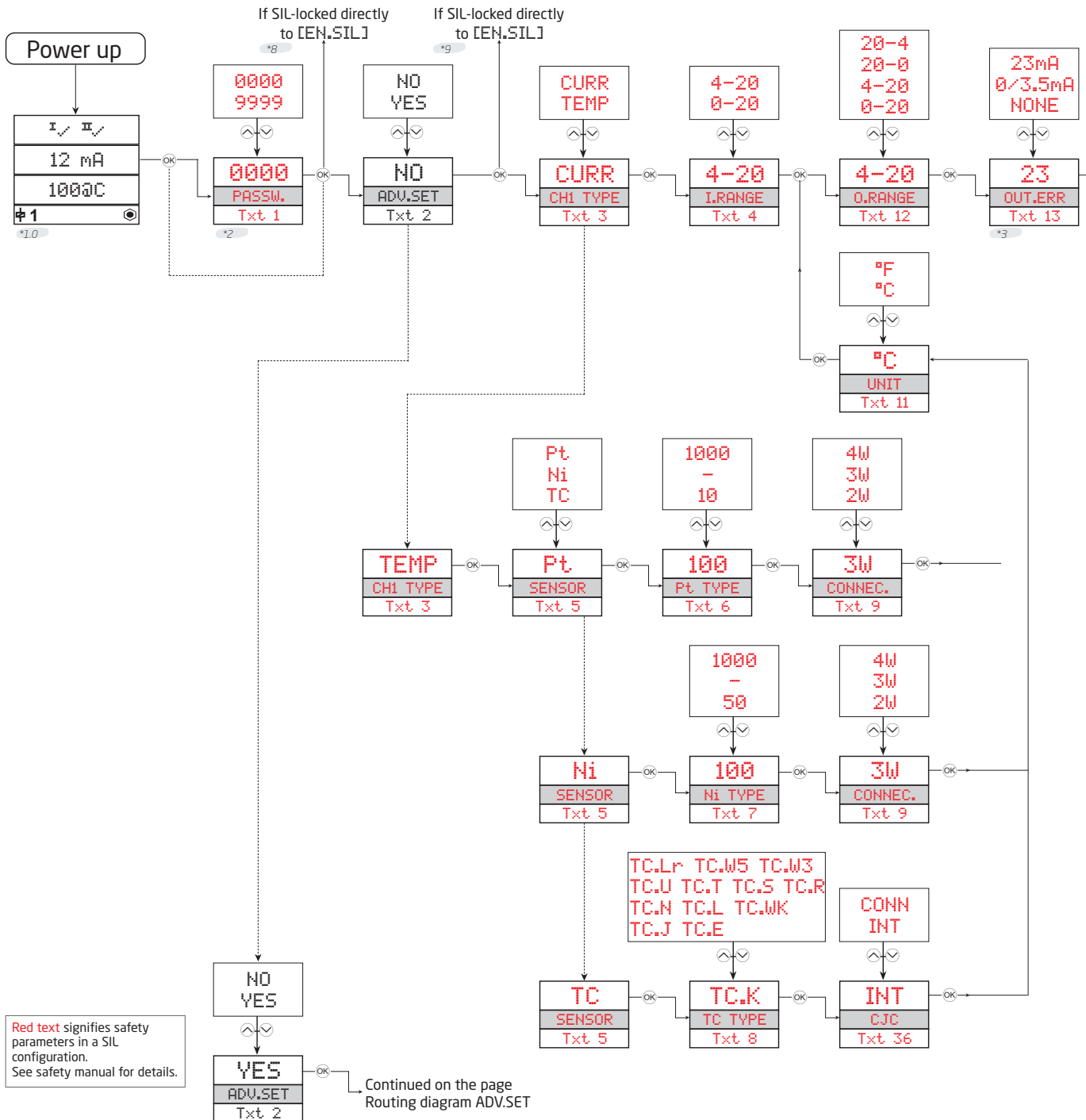

*1.0 Default state.
Line 1 shows input status
Line 2 and 3 show analog input / output value or TAG no. and units.
Line 4 shows status for communication and whether the device is SIL-locked.
Static dot = SIL-locked and flashing dot = not SIL-locked.

*2 Only if password-protected.

*3 Not valid for 0...20 mA input signal.

*4 Only if input signal is temperature.
Min. and max. acc. to selected sensor type

*8 Branching to SIL from this point valid for:
All 4501 devices.
4511 devices with serial no. lower than 211001001.
4512 devices with serial no. lower than 211065001.

*9 Branching to SIL from this point valid for:
4511 devices with serial no from 211001001.
4512 devices with serial no from 211065001.

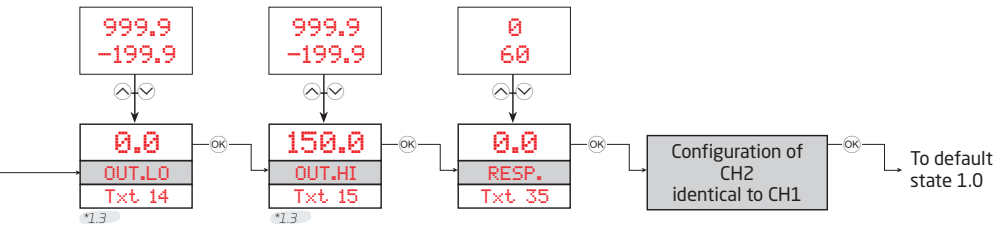

*6 Only if the configuration is not protected by a password.

*10 Not available on PR 4500 if SIL-locked.
Only for 4512 devices with serial no. from 211065001 and for 4511 devices with serial no. from 211001001.

16.3 Routing diagram, advanced settings (ADV.SET)

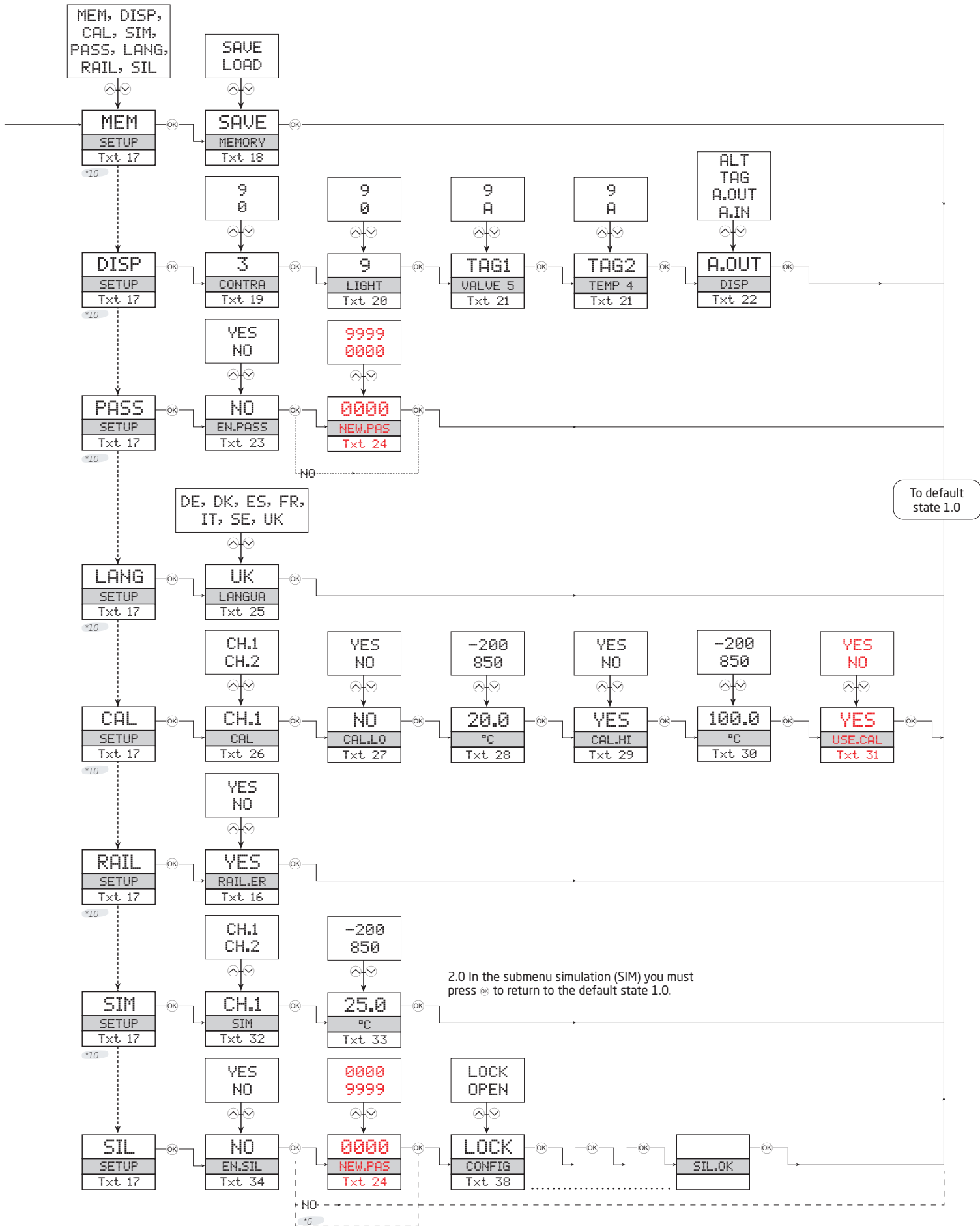

17. Connections diagram

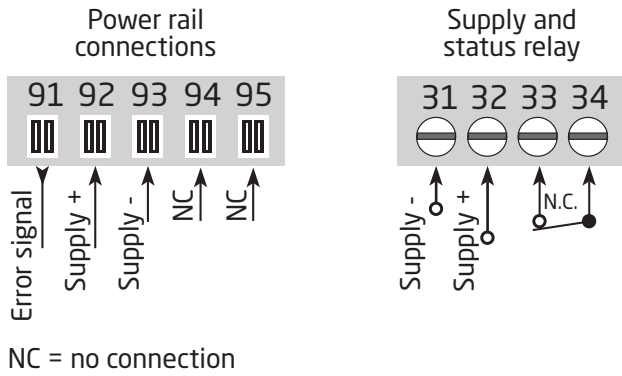

Inputs:

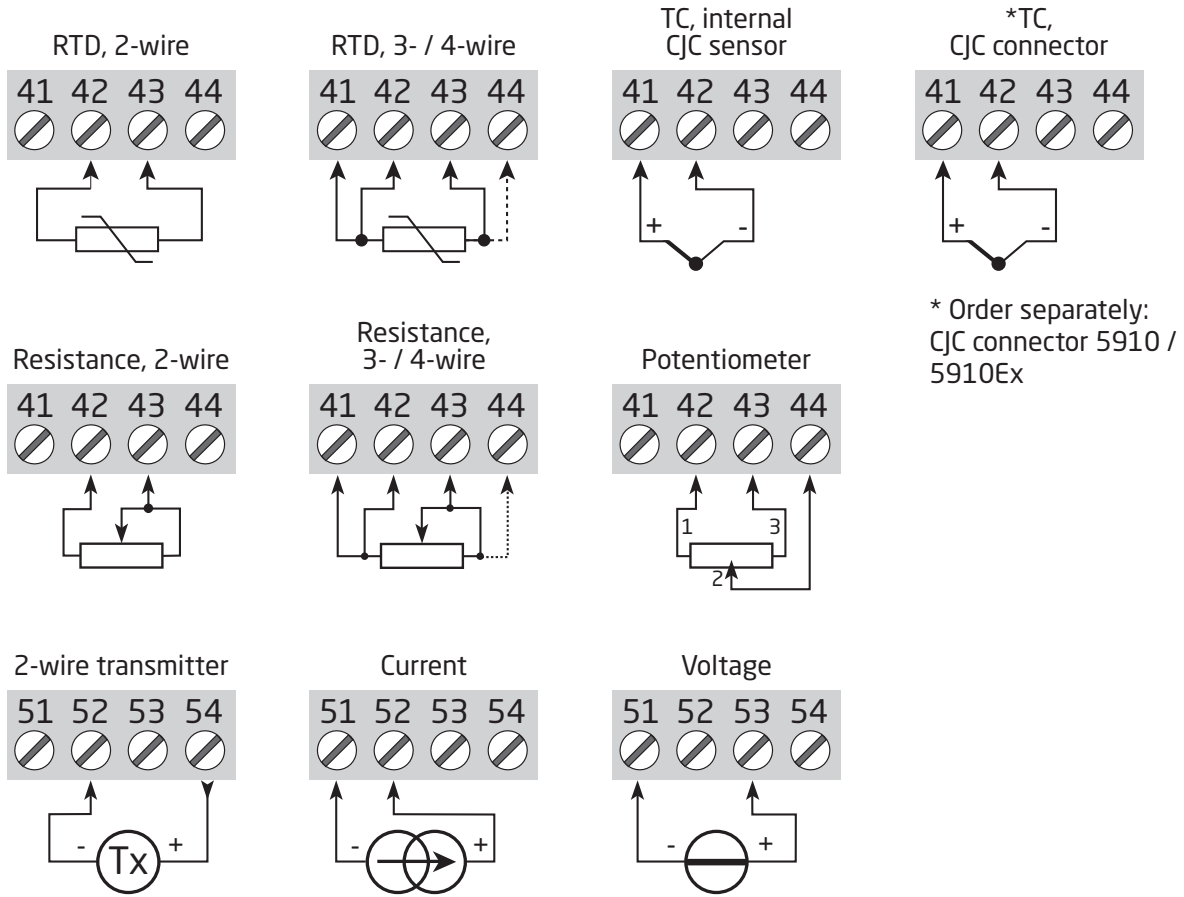

Outputs:

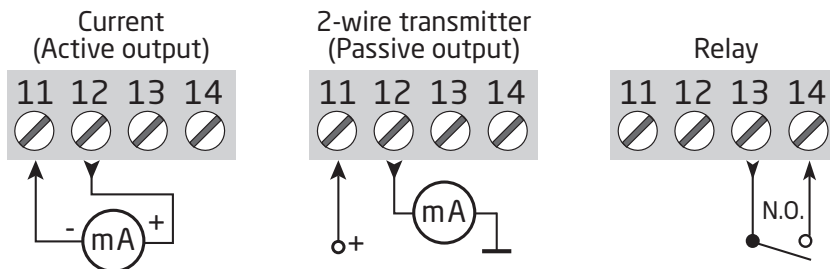

We are near you, *all over the world*

Our trusted red boxes are supported wherever you are

All our devices are backed by expert service and a 5-year warranty. With each product you purchase, you receive personal technical support and guidance, day-to-day delivery, repair without charge within the warranty period and easily accessible documentation.

We are headquartered in Denmark, and have offices and authorized partners the world over. We are a local

business with a global reach. This means that we are always nearby and know your local markets well. We are committed to your satisfaction and provide PERFORMANCE MADE SMARTER all around the world.

For more information on our warranty program, or to meet with a sales representative in your region, visit prelectronics.com.

Benefit today from *PERFORMANCE MADE SMARTER*

PR electronics is the leading technology company specialized in making industrial process control safer, more reliable and more efficient. Since 1974, we have been dedicated to perfecting our core competence of innovating high precision technology with low power consumption. This dedication continues to set new standards for products communicating, monitoring and connecting our customers' process measurement points to their process control systems.

Our innovative, patented technologies are derived from our extensive R&D facilities and from having a great understanding of our customers' needs and processes. We are guided by principles of simplicity, focus, courage and excellence, enabling some of the world's greatest companies to achieve PERFORMANCE MADE SMARTER.